

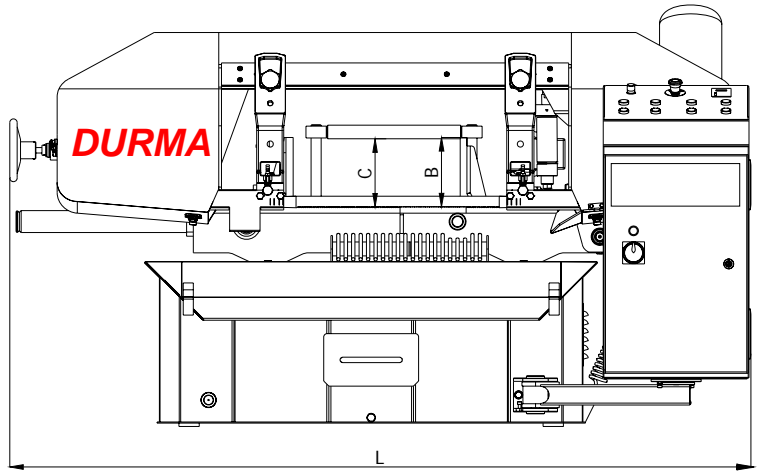

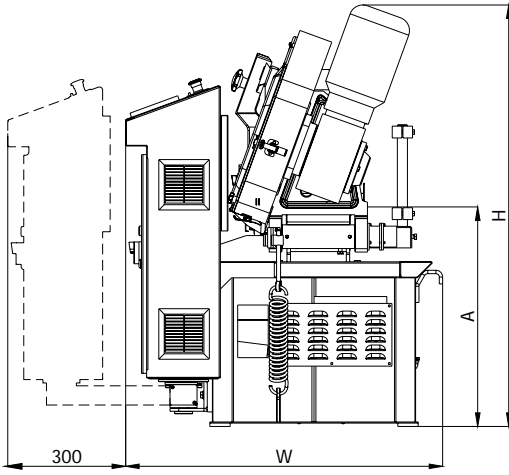



HB-S 330 TECHNICAL DATA

HB-S 330				Horizontal Semi-Automatic Band Saw		
Cutting Capacities	90°		Round	Inch	13"	
			Square	Inch	9½"	
			Rectangle	Inch	9½" x 19¾"	
	60°		Round	Inch	11¾"	
			Square	Inch	9"	
			Rectangle	Inch	9" x 14"	
	45°		Round	Inch	10¼"	
			Square	Inch	7¾"	
			Rectangle	Inch	7¾" x 11"	
	30°		Round	Inch	-	
			Square	Inch	-	
			Rectangle	Inch	-	
Motor	Main Motor			HP	3	
	Hydraulic Motor			HP	1/2	
	Material Rolling Motor			HP	-	
	Cooling Motor			HP	1/8	
Dimensions	Length	(L)	Inch	85"		
	Width	(W)	Inch	40"		
	Height	(H)	Inch	50"		
	Vice Height	(B)	Inch	7¾"		
	Mechanical Top Hold-down Height	(C)	Inch	7¾"		
Cutting Speed				Ft/Min	65 ~ 262 Inverter	
Band Size				Inch	1.3" x .04" x 168" (14')	
Working Height				(A)	Inch	25½"
Weight				Lbs.	1,544 Lbs.	
Band Twisting Angle				°	60°	