

HYDRAULIC 3-ROLLS

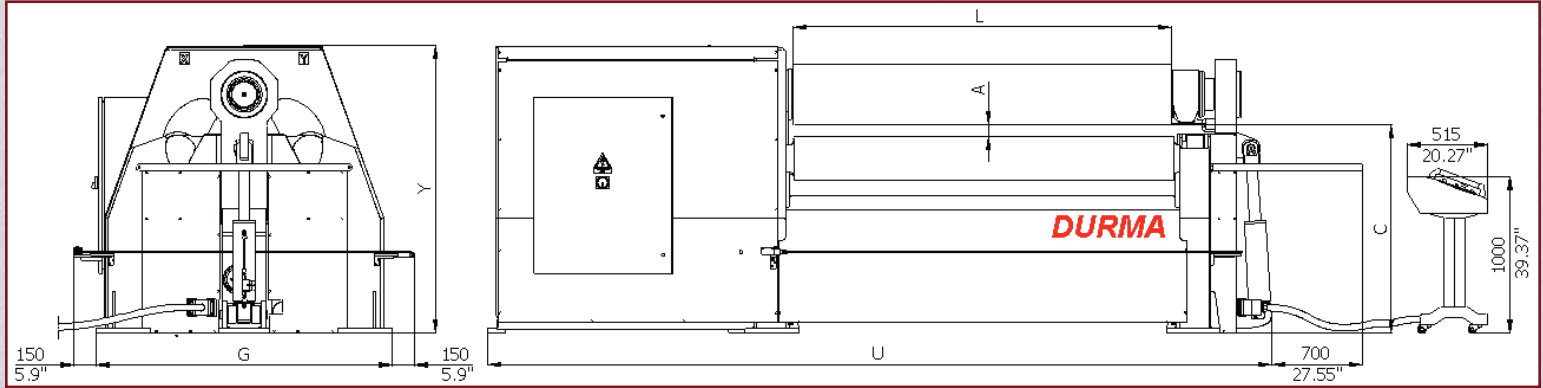

HRB-3 HYDRAULIC ROLL BENDING

Standard Specifications

- Control unit with 4 digital readouts
- Programmable multi-pass points
- Cone bending
- Hardened rolls (HRC 58)
- Highly durable forged 4140 alloy steel rolls machined by CNC Lathes with optimal crown (special crown upon request)
- Electronic control for side rolls
- Stress relieved steel construction machine frame
- All rolls mounted on bearings
- Hydraulic drop end with easy pull out system
- 1" pre-bend and above machines have rectilinear guides (planetary swing guides also available)
- All rolls are driven with a combination of hydraulic motor(s) and planetary gear box(es)
- Dual speed control

- Electrical and hydraulic protection against overloads
- World standard electrical and hydraulic components (parts stocked by us or are available off-the-shelf from your local supplier)

Optional Accessories

- Variable speed control
- Remote (wired or wireless)
- Oil cooling
- Side supports
- Vertical supports
- Material feed table
- Changeable top roll for smaller diameters
- Extended rolls for section bending
- Polished rolls
- Custom machines available

HYDRAULIC 3-ROLLS

Model	Bending Length (L)	Pre-Bending (1.5 x Top Roll Ø)	Pre-Bending (3 x Top Roll Ø)	Top Roll	Side Rolls	Max. Pass Through (A)	Working Height (C)	Length (U)	Width (G)	Height (Y)	LBS	HP
HRB-3 2006	6' 8"	5/32"	1/4"	7.28"	6.50"	2-3/4"	31.89	152"	52"	46"	5,512	5
HRB-3 2008	6' 8"	1/4"	5/16"	7.87"	7.09"	2-3/4"	32.28	152"	52"	46"	7,276	7
HRB-3 2010	6' 8"	5/16"	3/8"	8.66"	7.87"	2-3/16"	32.28	156"	56"	46"	8,819	10
HRB-3 2013	6' 8"	3/8"	1/2"	9.06"	8.27"	3-3/16"	35.43	156"	56"	56"	10,583	10
HRB-3 2016	6' 8"	1/2"	5/8"	10.63"	9.84"	4"	38.58	164"	65"	56"	13,228	15
HRB-3 2020	6' 8"	5/8"	25/32"	11.81"	10.63"	4"	40.55	164"	65"	56"	15,874	15
HRB-3 2025	6' 8"	25/32"	1"	12.99"	11.42"	4"	42.32	172"	75"	67"	20,503	20
HRB-3 2030	6' 8"	1"	1-3/16"	14.17"	12.60"	4"	48.62	172"	75"	67"	22,047	25
HRB-3 2035	6' 8"	1-3/16"	1-3/8"	16.14"	14.96"	4"	48.82	195"	83"	75"	28,661	40
HRB-3 2040	6' 8"	1-3/8"	1-9/16"	16.93"	15.35"	4"	56.30	195"	87"	79"	35,274	40
HRB-3 2050	6' 8"	1-9/16"	2"	17.72"	16.54"	4"	62.60	215"	91"	87"	41,888	50
HRB-3 2506	8' 4"	5/32"	1/4"	7.87"	7.09"	2-3/4"	32.28	152"	52"	46"	8,378	7
HRB-3 2508	8' 4"	1/4"	5/16"	8.66"	7.87"	2-3/16"	32.28	176"	56"	46"	9,921	10
HRB-3 2510	8' 4"	5/16"	3/8"	9.06"	8.27"	3-3/16"	35.43	176"	56"	56"	12,126	10
HRB-3 2513	8' 4"	3/8"	1/2"	10.63"	9.84"	4"	38.58	184"	65"	56"	14,771	15
HRB-3 2516	8' 4"	1/2"	5/8"	11.81"	10.63"	4"	40.55	184"	65"	56"	17,637	15
HRB-3 2520	8' 4"	5/8"	25/32"	12.99"	11.42"	4"	42.32	191"	75"	67"	22,929	20
HRB-3 2525	8' 4"	25/32"	1"	14.17"	12.60"	4"	48.62	191"	75"	67"	25,354	25
HRB-3 2530	8' 4"	1"	1-3/16"	16.14"	14.96"	4"	48.82	215"	83"	75"	33,070	40
HRB-3 2535	8' 4"	1-3/16"	1-3/8"	16.93"	15.35"	4"	56.30	215"	87"	79"	41,888	40
HRB-3 2540	8' 4"	1-3/8"	1-9/16"	17.72"	16.54"	4"	62.60	235"	91"	87"	50,707	50
HRB-3 3006	10' 2"	5/32"	1/4"	8.66"	7.87"	2-3/16"	32.28	197"	56"	46"	11,024	10
HRB-3 3008	10' 2"	1/4"	5/16"	9.06"	8.27"	3-3/16"	35.43	197"	56"	56"	13,228	10
HRB-3 3010	10' 2"	5/16"	3/8"	10.63"	9.84"	4"	38.58	205"	65"	56"	16,535	15
HRB-3 3013	10' 2"	3/8"	1/2"	11.81"	10.63"	4"	40.55	205"	65"	56"	19,842	15
HRB-3 3016	10' 2"	1/2"	5/8"	12.99"	11.42"	4"	42.32	213"	75"	67"	26,015	20
HRB-3 3020	10' 2"	5/8"	25/32"	14.17"	12.60"	4"	48.62	213"	75"	67"	33,500	25
HRB-3 3025	10' 2"	25/32"	1"	16.14"	14.96"	4"	48.82	237"	83"	75"	37,479	40
HRB-3 3030	10' 2"	1"	1-3/16"	16.93"	15.35"	4"	56.30	237"	87"	79"	46,298	40
HRB-3 3035	10' 2"	1-3/16"	1-3/8"	17.72"	16.54"	4"	62.60	256"	91"	87"	55,116	50
HRB-3 3040	10' 2"	1-3/8"	1-9/16"	18.50"	17.72"	4"	68.90	256"	91"	87"	66,139	60
HRB-3 3050*	10' 2"	1-9/16"	2"	20.47"	19.29"	6"	74.80	264"	107"	99"	83,776	70
HRB-3 4006	13' 5"	5/32"	1/4"	10.63"	9.84"	4"	38.58	245"	65"	56"	19,842	15
HRB-3 4008	13' 5"	1/4"	5/16"	11.81"	10.63"	4"	40.55	245"	65"	56"	24,251	15
HRB-3 4010	13' 5"	5/16"	3/8"	12.99"	11.42"	4"	42.32	252"	75"	67"	30,865	20
HRB-3 4013	13' 5"	3/8"	1/2"	14.17"	12.60"	4"	48.62	252"	75"	67"	39,684	25
HRB-3 4016	13' 5"	1/2"	5/8"	16.14"	14.96"	4"	48.82	276"	83"	75"	48,502	40
HRB-3 4020	13' 5"	5/8"	25/32"	16.93"	15.35"	4"	56.30	276"	87"	79"	55,116	40
HRB-3 4025	13' 5"	25/32"	1"	17.72"	16.54"	4"	62.60	296"	91"	87"	66,139	50
HRB-3 4030	13' 5"	1"	1-3/16"	18.50"	17.72"	4"	68.90	296"	91"	87"	74,958	60
HRB-3 4035*	13' 5"	1-3/16"	1-3/8"	20.47"	18.50"	6"	74.80	304"	107"	99"	103,618	70

Standard machine specifications. **Custom machines available upon request.**

* For models marked with an asterisk: Ø Dmin = Ødx2 (prebending); Ødx4 (bending). Above info for Class 2 material (mild steel). For different materials, please consult your sales representative. Bending capacities may have to be reduced for conical bending.



JORGENSON MACHINE TOOLS
A JORGENSON COMPANY

Custom Machines Built to Order
All Specifications Subject to Verification

Toll Free: **800-952-0151**
Phone: **801-493-0151** • Fax: **801-493-0157**
www.JorgensonMachineTools.com
sales@JorgensonCompanies.com