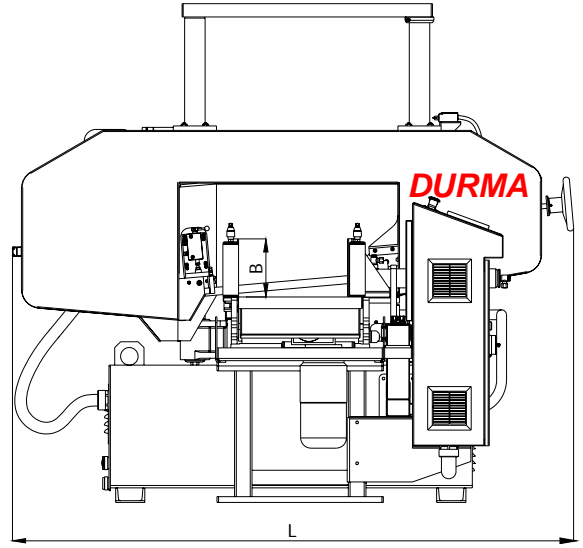
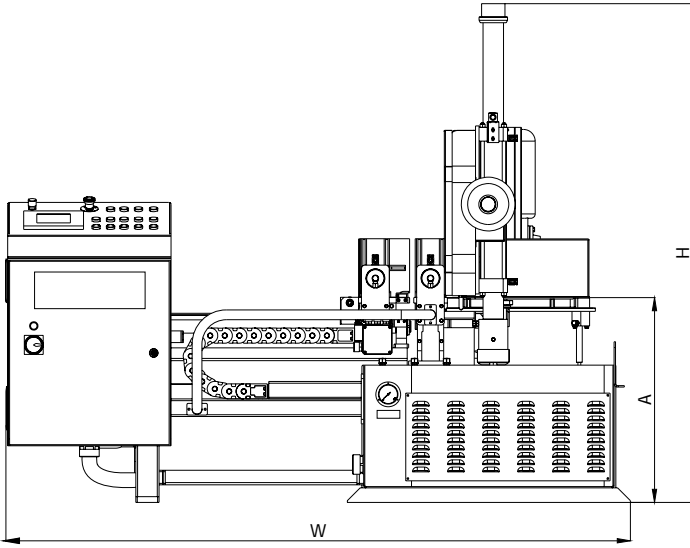

DCB-FA 330 TECHNICAL DATA

DCB-FA 330					Double Column Automatic Miter Band Saw	
Cutting Capacities	90°	○	Round	Inch	13"	
		□	Square	Inch	13"	
		▭	Rectangle	Inch	13" x 14½"	
	60°	○	Round	Inch	12¼"	
		□	Square	Inch	12¼"	
		▭	Rectangle	Inch	13" x 12¼"	
	45°	○	Round	Inch	8½"	
		□	Square	Inch	8½"	
		▭	Rectangle	Inch	13" x 8½"	
	30°	○	Round	Inch	4¾"	
		□	Square	Inch	4¾"	
		▭	Rectangle	Inch	13" x 4¾"	
Motor	Main Motor			HP	2	
	Hydraulic Motor			HP	3/4	
	Material Rolling Motor			HP	1½	
	Cooling Motor			HP	1/8	
Dimensions	Length (L)			Inch	77"	
	Width (W)			Inch	85"	
	Height (H)			Inch	68"	
	Vice Height (B)			Inch	7¾"	
Cutting Speed				Ft/Min	65 ~ 328 Inverter	
Band Size				Inch	1" x .035" x 154" (12¾')	
Working Height (A)				Inch	27½"	
Weight				Lbs.	2,646 Lbs.	
Band Twisting Angle				°	90°	